

MACCHINA MANUALE AD ANELLO ROTANTE PER L'AVVOLGIMENTO A SPIRALE CON FILM ESTENSIBILE

Manual rotating ring machine for spiral wrapping with stretch film

Machine manuelle à anneau tournant pour le banderolage en spirale avec un film tirable

Máquina manual de aro giratorio para envolver en espiral con film extensible

Manuell gesteuerte maschine mit drehring zum spiralwickeln mit stretchfolie

Wrappy^m



www.noxon.it



Wrappy m4, m6, m9, m12



- **Piani regolabili in altezza**
- Height adjustable conveyor
- Hauteur plans réglables
- Plano ajustable en altura
- Verstellbare arbeitstische

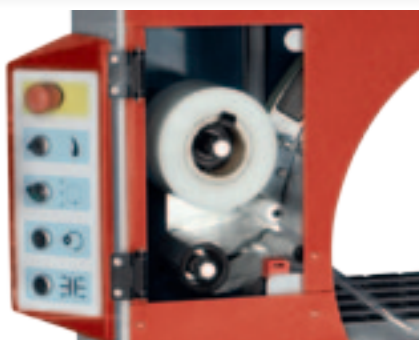

- **Gruppo portabobina**
- Spool carriage unit
- Groupe porte-bobine
- Grupo portabobina
- Rollenhalter



- **Gruppo pinza e taglio**
- Cutting and clamping unit
- Groupe pince et coupe
- Grupo pinza y corte
- Zangen- und schnittaggregat

Dimensioni lavorabili Wrappy m4, m6, m9, m12

Working dimensions

Dimensions admissibles

Dimensiones laborables

Bearbeitbare abmessungen

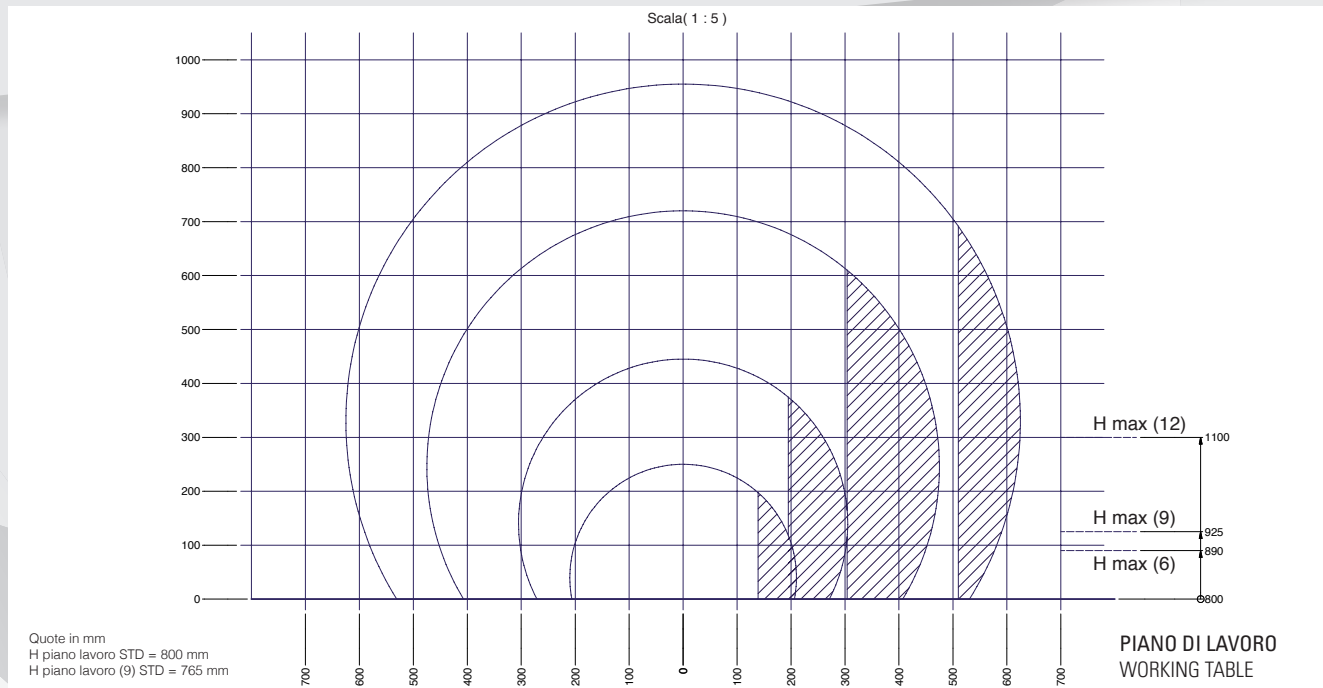

Hmin.Piano di lavoro/ Working table/Plan de travail/Plano de trabajo/Arbeitsfläche (standard 800mm) Wrappy M12 (standard 810mm)

Hmax.Piano di lavoro/ Working table maximum height/Hauteur maximale plan de travail/Altura máxima del plano de trabajo/Maximale Höhe der Arbeitsfläche:(Wrappy M4: 800mm - Wrappy M6: 890mm - Wrappy M9: 925 mm - Wrappy M12: 1100mm)

DIMENSIONI MINIME LAVORABILI/ MINIMUM WORKABLE DIMENSIONS/DIMENSIONS MINIMALES ADMISSIBLES/DIMENSIONES MINIMAS LABORABLES/MINIMAL BEARBEITBARE ABMESSUNGEN: Wrappy M4: 50x50mm - Wrappy M6: 70x70mm - Wrappy M9: 90x90mm - Wrappy M12: 150x150mm

DIMENSIONI MACCHINA/ MACHINE DIMENSIONS/DIMENSIONS MACHINE/DIMENSIONES MAQUINA/MASCHINENABMESSUNGEN				
MACCHINA/MACHINE/ MÁQUINA/MASCHINE	m4	m6	m9	m12
Lmm	1010	1010	1400	2385
Wmm	1234	1400	1930	2375
Hmm	1340	1550	1850	2175
H'mm	800	800+890	800+950	800+1100
Xmm	350	450	715	910

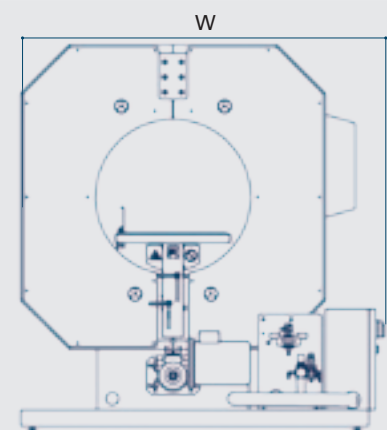
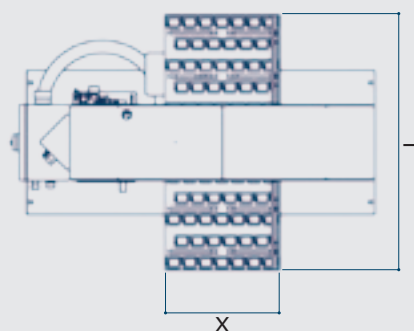
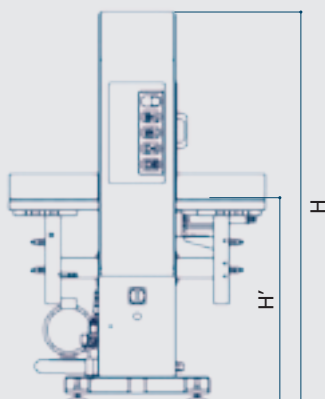

CARATTERISTICHE TECNICHE/ TECHNICAL SPECIFICATIONS/ SPÉCIFICATIONS/ ESPECIFICACIONES/ TECHNISCHE DATEN

MACCHINA/MACHINE/ MÁQUINA/MASCHINE	m4	m6	m9		m12
Larghezza bobina/Spool width/Largeur bobine/Ancho bobina/Folienbreite mm	125	125	125	250	125-250
Gruppo rotazione con trascinamento a cinghia/ Belt driven rotation unit/Groupe rotation avec entraînement par courroie/Grupo rotación con arrastre mediante cinta/Drehaggregat mit Riemen-Mitnehmer	x	x	x	x	x
Velocità rotazione max/Max rotation speed/Vitesse rotation max/Velocidad máx de rotación/Max Drehzahl	150 rpm	120 rpm	75 rpm	60 rpm	58 rpm
Gruppo pinza e taglio pneumatico/Pneumatically cutting and clamping unit/Groupe pince et coupe pneumatique/Unidad de sujeción y corte neumático	x	x	x	x	x
Gruppo portabobina a rullo frizionato di rinvio/ Spool unit with frictioned roll/Groupe porte-bobine avec rouleau frein/Grupo portabobina de rodillo friccionado de retorno/Pneumatisches Zangen- und Kaltschnittaggregat	x	x	x	x	x
Tensione di alimentazione/Power supply voltage/ Tension d'alimentation/Tensión de alimentación/ Versorgungsspannung	230V1Ph+ N50 60Hz	230V1Ph+ N50 60Hz	230V1Ph+ N50 60Hz	400V3Ph+ N50 60Hz	400V3Ph+ N50 60Hz
Potenza installata/Installed power/Puissance installée/Potencia instalada/Installierte Leistung	0,55 kW	0,75 kW	0,75 kW	0,75 kW	1,5 kW
Pressione di esercizio/Working pressure/Pression de service/Presión de ejercicio/Betriebsdruck	6±1bar	6±1bar	6±1bar	6±1bar	6±1bar
Consumo di aria compressa/Compressed air consumption/Consommation d'air comprimé/ Consumo de aire comprimido/Druckluftverbrauch (NI/ciclo)(NI/cycle)	1,8	1,8	1,8	3,2	3,2

CARATTERISTICHE FILM/ FILM FEATURES/CARACTÉRISTIQUES DU FILM/CARACTERÍSTICAS DE LA PELÍCULA/FILM FEATURES

Diametro esterno bobina max/Spool max external diameter/Diamètre extérieur bobine max/Diámetro externo máx bobina/Max. Außendurchmesser Spule (mm)	200	200	200	250	250
Diametro interno bobin/Core diameter/Diamètre intérieur bobine/Diámetro interior bobina/ Innendurchmesser Spule (mm)	76mm	76mm	76mm	76mm	76mm



NOXON S.p.A.
Strada Degli Angariari, 6
47891 Falciano
(Repubblica di San Marino)

Tel. +378 0549 941426
fax +378 0549 977419
info@noxon.it